

MANUAL TOOLING GUIDE

www.pemnet.com

For Series LT/4® Press



CONTENTS



Manual Tooling Guide

For Series LT/4® Press

NOTE: The Series LT/4 press is designed to generate a ram force of 6000 lbs / 26.7kN. The press will install fasteners that require less than 6,000 lbs / 26.7kN of installation force. Please check the fastener and workpiece material specifications for the installation force necessary for your specific application.

*LT/4 press will install fastener into aluminum. Inserting into cold rolled steel may require more than 6,000 lbs/26.7kN of force.

**LT/4 press will not install these fasteners, they require more than 6,000 lbs / 26.7kN of force for installation.

	FASTENER DESCRIPTION	PAGE
◆ IDENTIFICATION DRAWINGS	MANUAL PUNCH AND ANVIL ASSEMBLIES	4-8
◆ AS, AC, LAS, LAC	SELF-CLINCHING FLOATING	9
◆ A4, LA4	STAINLESS SELF-CLINCHING FLOATING	9
◆ B, BS	BLIND NUT	9
◆ CFN, SLPS	CONNECT'R WARE FASTENERS	9
◆ CHA, CHC, CFHA, CFHC	CONCEALED HEAD STUD	9
◆ CLA	ALUMINUM SELF-CLINCHING NUTS	10
◆ CLS, CLSS, S, SS,	SELF-CLINCHING NUTS	10
◆ CSOS, CSS	CONCEALED HEAD STANDOFF	10
◆ DPRS, DBRS	WAVEGARD GROUNDING	10
◆ DSOS	THREADED STANDOFF CLOSE-TO-EDGE APPLICATIONS	10
◆ F	FLUSH NUTS	11
◆ FE, FEO, FEX, FEO	MINIATURE SELF-LOCKING NUTS	11
◆ FH, FHA, FHS	FLUSH STUDS	11
◆ FHL, FHLS	FLUSH STUDS FOR CLOSE-TO-EDGE APPLICATIONS ...	12
◆ FH4, FHP	SERIES 400 STAINLESS FLUSH STUDS	12
◆ FHX	FLUSH STUDS WITH X-PRESS™ THREADS	13
◆ HF109	HIGH STRENGTH STUDS	13
◆ HFE	HIGH STUDS	13
◆ HFG8	HIGH STRENGTH STUDS	13
◆ HFH, HFHS, HFHB	HIGH STRENGTH STUDS	14
◆ TFH, TFHS	NON FLUSH THIN SHEET	14
◆ H, HN, HNL	SELF-LOCKING & NON-LOCKING NUTS	14
◆ KF2, KFS2	BROACHING NUTS	15
◆ KFB3	FLARE-MOUNTED THREADED STANDOFF	15
◆ KFE, KFSE	BROACHING STANDOFF	16
◆ KFH	BROACHING STUDS	16
◆ KPS6	SELF-EXPANDING FOILGUARD FASTENERS	17
◆ KSSB	BROACHING SNAP-TOP STANDOFFS	17



Manual Tooling Guide

For Series LT/4® Press

NOTE: The Series LT/4 press is designed to generate a ram force of 6000 lbs / 26.7kN. The press will install fasteners that require less than 6,000 lbs / 26.7kN of installation force. Please check the fastener and workpiece material specifications for the installation force necessary for your specific application.

*LT/4 press will install fastener into aluminum. Inserting into cold rolled steel may require more than 6,000 lbs/26.7kN of force.

**LT/4 press will not install these fasteners, they require more than 6,000 lbs / 26.7kN of force for installation.

	FASTENER DESCRIPTION	PAGE
◆ <i>LK, LKS, LKA</i>	SELF-LOCKING NUTS	17
◆ <i>MPP</i>	MINIATURE PINS.....	18
◆ <i>MS04</i>	MINIATURE SELF-CLINCHING STANDOFFS.....	18
◆ <i>NFPC, NFPA</i>	INSERTS FOR PLASTICS	18
◆ <i>PFC2,PFC2P,PFC4, PFF, PFK PFS2, PF11, PF11MF, PF13, PF14, PF30, PF31, PF32, PF10, PF50, PF60, PF11MW</i>	PANEL FASTENERS	18-20
◆ <i>PFHV, FP, PFS</i>	PANEL FASTENER, SNAP-IN PANEL FASTENERS	20-21
◆ <i>PFVM, PFVMF</i>	PANEL FASTENER.....	21
◆ <i>PL, PLC</i>	PEM-HEX® SELF-LOCKING NUTS	22
◆ <i>PTL2</i>	SPRING-LOADED PLUNGER ASSEMBLIES	22
◆ <i>RAA, RAS</i>	RIGHT ANGLE CLINCH FASTENER	22
◆ <i>SCB/SCBJ</i>	SPINNING CLINCH BOLT.....	22
◆ <i>SCBR</i>	MAGNETIC PUNCH ASSEMBLIES.....	22
◆ <i>SF, SFP</i>	SPOT FASTENER	23
◆ <i>SFW</i>	SPOT FASTENER.....	23
◆ <i>SGPC</i>	SWAGING COLLAR STUDS.....	23
◆ <i>SKC</i>	KEYHOLE® STANDOFFS	24
◆ <i>SL</i>	SELF-CLINCHING LOCKNUTS	24
◆ <i>SMPS</i>	SELF-CLINCHING NUTS –ULTRA THIN SHEET	24
◆ <i>SO, SOA, SOS, SON, BSO, BSOA, BSOS, BSON, SOAG, SOSG</i>	STANDOFFS	24
◆ <i>SP</i>	300 STAINLESS STEEL SELF-CLINCHING NUTS.....	25
◆ <i>SSA, SSS, SSC, KSSB</i>	SNAP-TOP STANDOFFS	25
◆ <i>TDO</i>	SELF-CLINCHING CABLE-TIE HOOKS	26
◆ <i>TPS, TPXS</i>	FLUSH-MOUNTED PILOT PINS	26
◆ <i>TSO,TSOS,TSOA</i>	THREADED STANDOFFS FOR THIN SHEETS.....	26
◆ <i>TY-D</i>	CABLE TIE-MOUNT FASTENERS.....	27
◆ <i>U, UL</i>	MINIATURE SELF-CLINCHING FASTENERS.....	27
◆	TURRET ANVILS	27



Manual Tooling Guide

For Series LT/4® Press

NOTE: The Series LT/4 press is designed to generate a ram force of 6000 lbs / 26.7kN. The press will install fasteners that require less than 6,000 lbs / 26.7kN of installation force. Please check the fastener and workpiece material specifications for the installation force necessary for your specific application.

*LT/4 press will install fastener into aluminum. Inserting into cold rolled steel may require more than 6,000 lbs/26.7kN of force.

**LT/4 press will not install these fasteners, they require more than 6,000 lbs / 26.7kN of force for installation.

◆	FASTENER DESCRIPTION	PAGE
◆	QX4™ TURRET TOOL SYSTEM	28
◆	BOTTOM MOUNT REVERSE FLANGE ANVIL HOLDER FOR SERIES 4 & LT/4 PRESS	28
◆	WORKPIECE ALIGNMENT PLATES KIT	28
◆	TOOLING AND ANVIL ADAPTERS	29
◆	SWAGE STANDOFFS	30-31
◆	PRESS ACCESSORIES	32

NOTE: The Series LT/4 press is designed to generate a ram force of 6000 lbs / 26.7kN. The press will install fasteners that require less than 6,000 lbs / 26.7kN of installation force. Please check the fastener and workpiece material specifications for the installation force necessary for your specific application.

*LT/4 press will install fastener into aluminum. Inserting into cold rolled steel may require more than 6,000 lbs/26.7kN of force.

**LT/4 press will not install these fasteners, they require more than 6,000 lbs / 26.7kN of force for installation.

PUNCH ASSEMBLY DRAWINGS

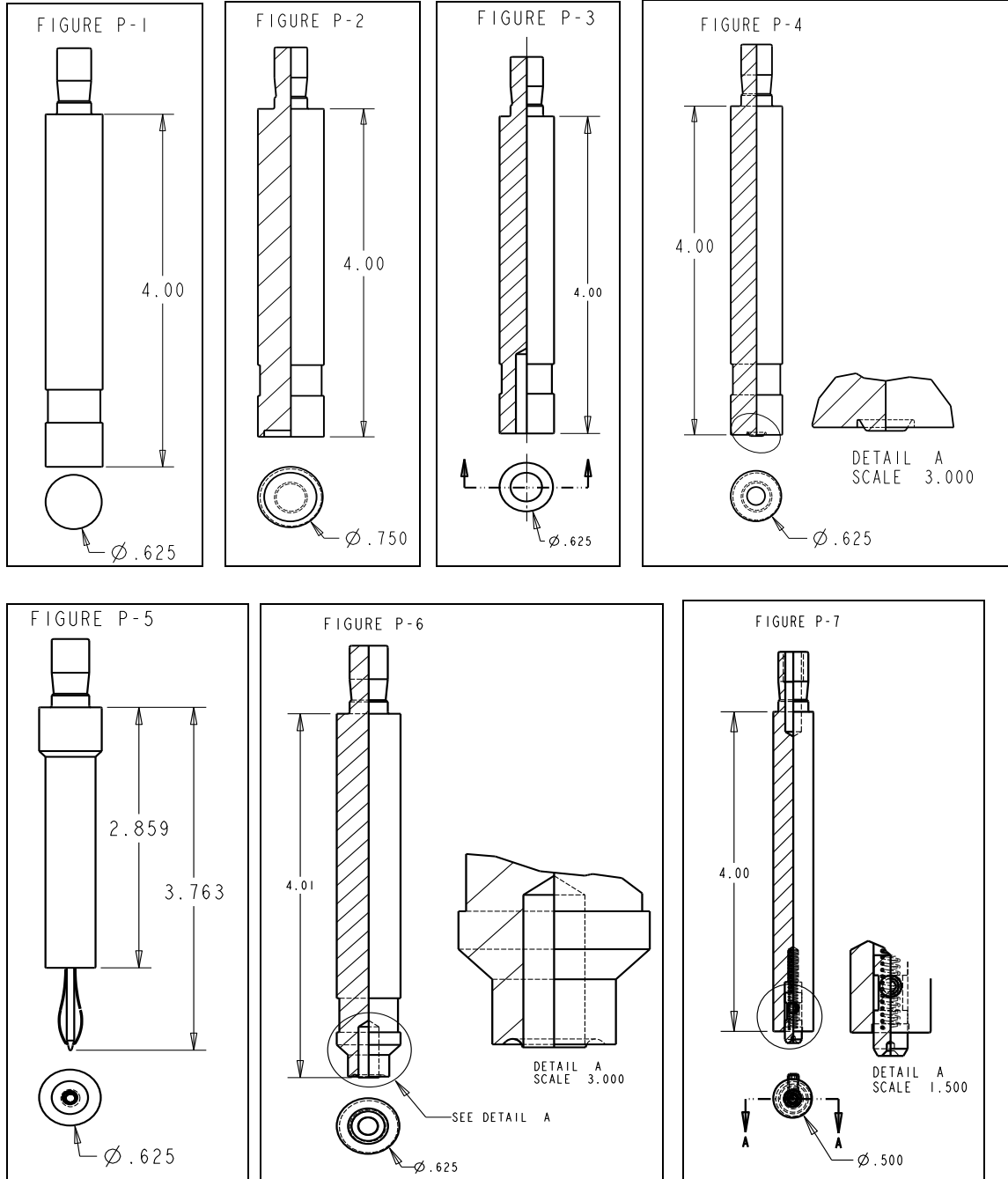

* Standard Length for Punches is 4" (101.6mm) and Anvils 3" (76.2mm). Most punches and anvils are 5/8" (15.9mm) in diameter. All are designed to fit the 3/8" (9.5mm) punch and anvil adapters of Pemsrter® presses. All tooling includes yellow shrink tubing in groove as warning for possible pinch point.



Manual Tooling Guide

For Series LT/4® Press

NOTE: The Series LT/4 press is designed to generate a ram force of 6000 lbs / 26.7kN. The press will install fasteners that require less than 6,000 lbs / 26.7kN of installation force. Please check the fastener and workpiece material specifications for the installation force necessary for your specific application.

*LT/4 press will install fastener into aluminum. Inserting into cold rolled steel may require more than 6,000 lbs/26.7kN of force.

**LT/4 press will not install these fasteners, they require more than 6,000 lbs / 26.7kN of force for installation.

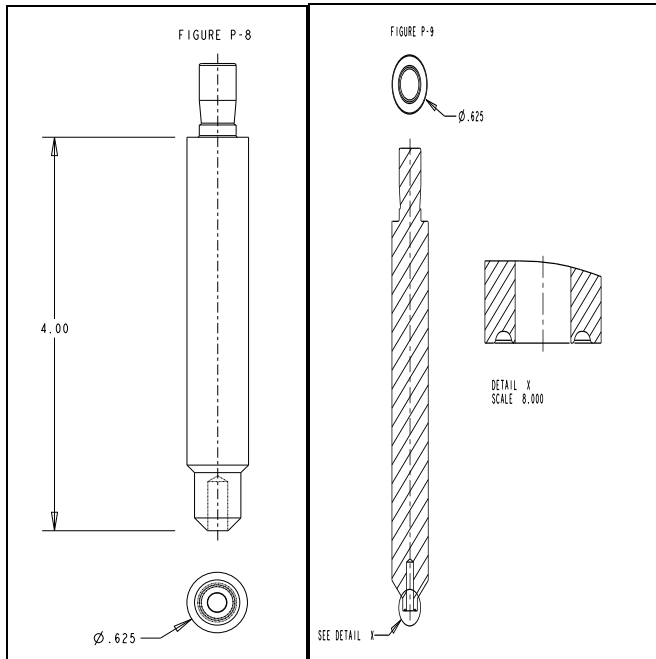

* Standard Length for Punches is 4” (101.6mm) and Anvils 3” (76.2mm). Most punches and anvils are 5/8” (15.9mm) in diameter. All are designed to fit the 3/8” (9.5mm) punch and anvil adapters of Pemsrter® presses. All tooling includes yellow shrink tubing in groove as warning for possible pinch point.

NOTE: The Series LT/4 press is designed to generate a ram force of 6000 lbs / 26.7kN. The press will install fasteners that require less than 6,000 lbs / 26.7kN of installation force. Please check the fastener and workpiece material specifications for the installation force necessary for your specific application.

*LT/4 press will install fastener into aluminum. Inserting into cold rolled steel may require more than 6,000 lbs/26.7kN of force.

**LT/4 press will not install these fasteners, they require more than 6,000 lbs / 26.7kN of force for installation.

ANVIL ASSEMBLY DRAWINGS

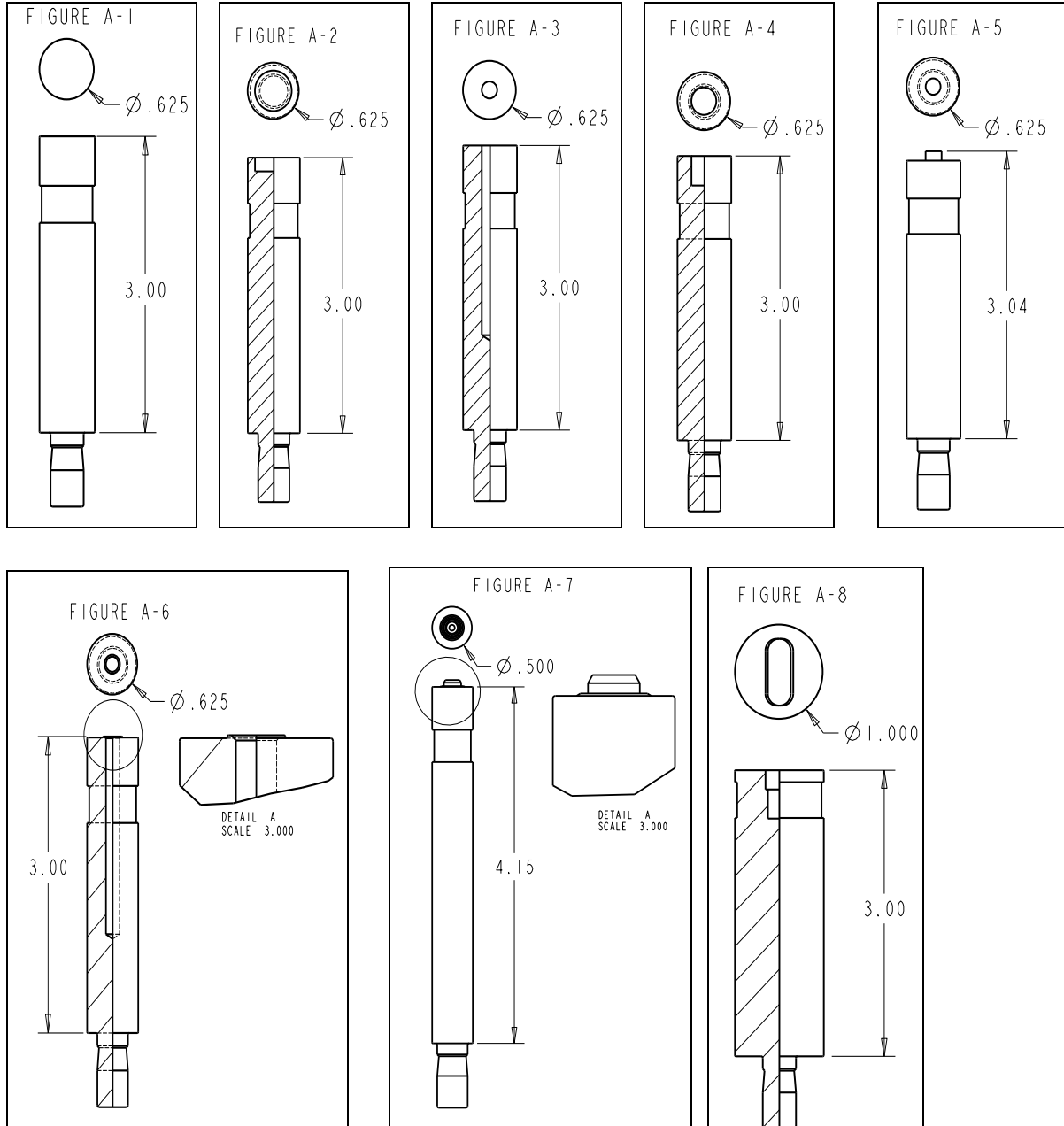

* Standard Length for Punches is 4" (101.6mm) and Anvils 3" (76.2mm). Most punches and anvils are 5/8" (15.9mm) in diameter. All are designed to fit the 3/8" (9.5mm) punch and anvil adapters of Pemsrter® presses. All tooling includes yellow shrink tubing in groove as warning for possible pinch point.

NOTE: The Series LT/4 press is designed to generate a ram force of 6000 lbs / 26.7kN. The press will install fasteners that require less than 6,000 lbs / 26.7kN of installation force. Please check the fastener and workpiece material specifications for the installation force necessary for your specific application.

*LT/4 press will install fastener into aluminum. Inserting into cold rolled steel may require more than 6,000 lbs/26.7kN of force.

**LT/4 press will not install these fasteners, they require more than 6,000 lbs / 26.7kN of force for installation.

ANVIL ASSEMBLY DRAWINGS (Continued)

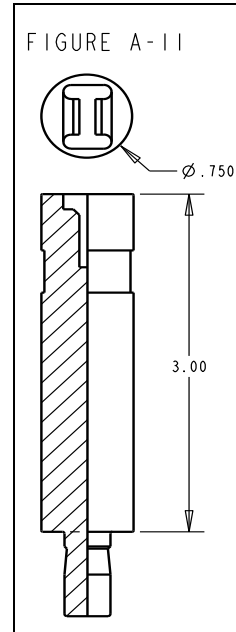
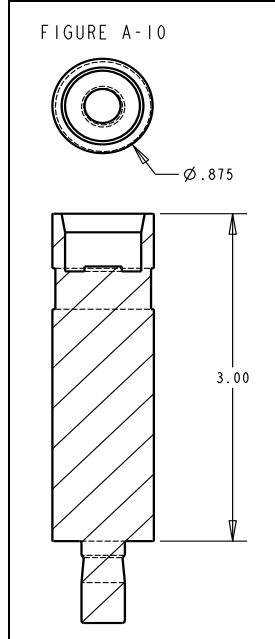
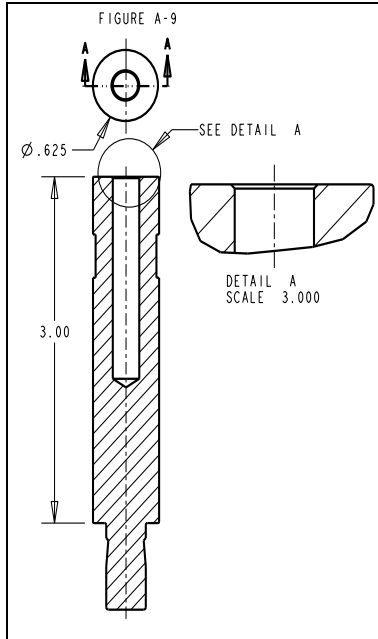

* Standard Length for Punches is 4" (101.6mm) and Anvils 3" (76.2mm). Most punches and anvils are 5/8" (15.9mm) in diameter. All are designed to fit the 3/8" (9.5mm) punch and anvil adapters of Pemsrter® presses. All tooling includes yellow shrink tubing in groove as warning for possible pinch point.

1/2" Tooling Adapter –
P/N 8007647

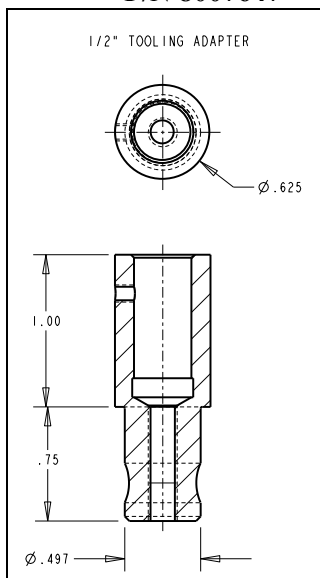

Anvil Adapter –
P/N 8010778, 8010779 & 8010780

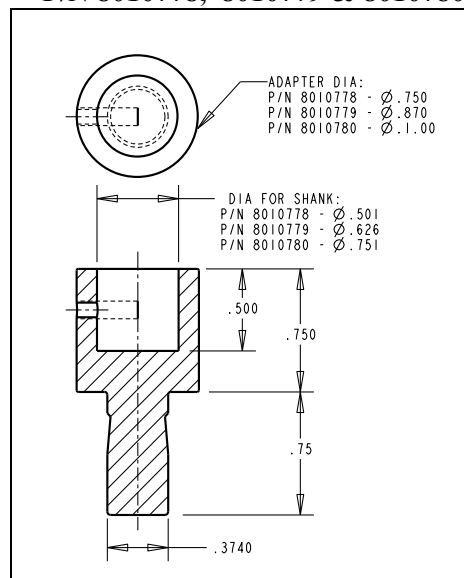



Manual Tooling Guide

For Series LT/4® Press

NOTE: The Series LT/4 press is designed to generate a ram force of 6000 lbs / 26.7kN. The press will install fasteners that require less than 6,000 lbs / 26.7kN of installation force. Please check the fastener and workpiece material specifications for the installation force necessary for your specific application.

*LT/4 press will install fastener into aluminum. Inserting into cold rolled steel may require more than 6,000 lbs/26.7kN of force.

**LT/4 press will not install these fasteners, they require more than 6,000 lbs / 26.7kN of force for installation.

AS, AC, LAS, LAC PEM® SELF-CLINCHING FLOATING – BULLETIN ALA

Size	Punch	Anvil
440/M3	975200048	975200006
632/M3.5		8013890
832/M4		8013891
1032/M5		8013892
0420/M6		975200010

Figure P-1

Figure A-4

A4, LA4 PEM® STAINLESS SELF-CLINCHING FLOATING – BULLETIN ALA

Size	Punch	Anvil
440/M3	975200048	8013889
632/M3.5		8013890
832/M4		8013891
1032/M5		8013892

Figure P-1

Figure A-4

B, BS PEM® BLIND NUT – BULLETIN B

Size	Punch	Anvil
440/M3	975200048	975200001
632/M3.5		975200002
832/M4		975200003
1032/M5		975200004
0420/M6		975200005

Figure P-1

Figure A-4

CFN, SLPS PEM® CONNECT'R WARE FASTENERS – BULLETIN CW

Size	Punch	Anvil
440/M3	975200048	8012038

Figure P-1

Figure A-4

CHA, CHC, CFHA, CFHC PEM® CONCEALED-HEAD STUD – BULLETIN CH

Size	Punch	Anvil
440	975200048	970200006300
632/M3.5		970200007300
832		970200008300
1032		970200009300
M3		970200229300
M4		970200019300
M5		970200020300

Figure P-1

Figure A-3

NOTE: THESE ANVILS ARE SAME AS FH ANVILS



Manual Tooling Guide

For Series LT/4® Press

NOTE: The Series LT/4 press is designed to generate a ram force of 6000 lbs / 26.7kN. The press will install fasteners that require less than 6,000 lbs / 26.7kN of installation force. Please check the fastener and workpiece material specifications for the installation force necessary for your specific application.

*LT/4 press will install fastener into aluminum. Inserting into cold rolled steel may require more than 6,000 lbs/26.7kN of force.

**LT/4 press will not install these fasteners, they require more than 6,000 lbs / 26.7kN of force for installation.

CLA PEM® ALUMINUM SELF-CLINCHING NUTS – BULLETIN CL

Size	Punch	Anvil
256/440/M2/M3	975200048	975200034
632/M3.5		975200035
832/M4		975200036
1032/M5		975200782300
0420/M6		975200038

NOTE: THESE ANVILS ARE SAME AS CLS, S ANVILS EXCEPT FOR 1032/M5.

Figure P-1

Figure A-2

CLS, CLSS, S, SS PEM® SELF-CLINCHING NUTS – BULLETIN CL

Size	Punch	Anvil
256/440/M2/M3	975200048	975200034
632/M3.5		975200035
832/M4		975200036
1032/M5*		975200037
12-24*		975200786300
0420/M6*		975200038
0518/M8**		975200039
0616**		975200045*
M10**		975200901400
0813/M12**	975200900300*	

Anvil ¾" (19mm) dia

Punch & Anvil 13/16" (20.6mm) dia

Figure P-1

Figure A-2 / *Figure A-5

*LARGE NUT ANVILS INSTEAD OF COUNTER BORE, USE PROTRUSION TO LOCATE PART.

CSOS, CSS PEM® CONCEALED-HEAD STANDOFF – BULLETIN CH

Size	Punch	Anvil
440/M3	975200048	970200014300
632/M3.5		970200015300
832/M4		970200016300
1032/M5		970200017300
0420/M6		970200018300

NOTE: THESE ANVILS ARE DIFFERENT THAN SO ANVILS

Figure P-1

Figure A-3

DPRS, DBRS PEM® WAVEGARD GROUNDING – BULLETIN DR

PACKAGE CONTAINS 2 PUNCHES AND 1 ANVIL	975201209
Anvil DBRS/DPRS – 975201224 : Punch DBRS – 975201208 : Punch DPRS – 975201225	

DSOS PEM® THREADED STANDOFF FOR CLOSE-TO-EDGE APPLICATIONS – BULLETIN SO

Size	Punch	Anvil
440/M3	975200048	970200487300

Figure P-1

Figure A-3



Manual Tooling Guide

For Series LT/4® Press

NOTE: The Series LT/4 press is designed to generate a ram force of 6000 lbs / 26.7kN. The press will install fasteners that require less than 6,000 lbs / 26.7kN of installation force. Please check the fastener and workpiece material specifications for the installation force necessary for your specific application.

*LT/4 press will install fastener into aluminum. Inserting into cold rolled steel may require more than 6,000 lbs/26.7kN of force.

**LT/4 press will not install these fasteners, they require more than 6,000 lbs / 26.7kN of force for installation.

F PEM® FLUSH NUTS – BULLETIN F

Size	Punch	Anvil
256/M2/M2.5	975200048	8006193
440/M3		975200040
632/M3.5		975200041
832/M4		975200042
1032/M5		975200043
0420/M6		975200044

Figure P-1

Figure A-5

FE, FEO, FEX, FEO PEM® MINIATURE, SELF-LOCKING NUTS – BULLETIN FE

Size	Punch	Anvil
440/M3	975200048	975200021
632/M3.5		975200022
832/M4		975200023
1032/M5		975200024
0420		975200025
M6		8013143

Figure P-1

Figure A-4

FH, FHA, FHS PEM® FLUSH STUDS – BULLETIN FH

Size	Punch	Anvil		
		For material .060"+/1.51mm+	For material <= .059"/1.5mm	
256	975200048	970200005300	970200240300	
440		970200006300	970200241300	
632/M3.5		970200007300	970200243300	
832*		970200008300	970200245300	
1032/024*		970200009300	970200246300	
0420**		970200010300	970200249300	
M2		8008451	8008452	
M2.5		970200300300	970200493300	
M3		970200229300	970200242300	
M4*		970200019300	970200244300	
M5*		970200020300	970200247300	
M6*		970200230300	970200248300	
			For material .075"+/1.9mm+	For material <= .074"/1.9mm
0518**		975200048	970200011300	970200250300
M8**	970200231300		970200251	

Figure P-1

Figure A-3

Figure A-9



Manual Tooling Guide

For Series LT/4® Press

NOTE: The Series LT/4 press is designed to generate a ram force of 6000 lbs / 26.7kN. The press will install fasteners that require less than 6,000 lbs / 26.7kN of installation force. Please check the fastener and workpiece material specifications for the installation force necessary for your specific application.

*LT/4 press will install fastener into aluminum. Inserting into cold rolled steel may require more than 6,000 lbs/26.7kN of force.

**LT/4 press will not install these fasteners, they require more than 6,000 lbs / 26.7kN of force for installation.

FHL, FHLS-PEM® FLUSH STUDS FOR CLOSE-TO-EDGE & MINIMAL SPACE APPLICATIONS BULLETIN FH

Size	Punch	Anvil For material .060"+/1.51mm+	Anvil For material <= .059"/1.5mm
256	975200997	8003313	8003297
440		8003618	8003298
632		8003314	8003299
832		8003315	8003300
1032		8003619	8003301
M2.5	975200997	8003316	8003302
M3		8003317	8003303
M3.5		8003318	8003304
M4		8003620	8003305
M5		8003319	8003306

*Figure P-1 –
½" (12.7mm) dia*

*Figure A-3 -
½" (12.7mm) dia*

*Figure A-9 –
½" (12.7mm) dia*

FH4 PEM® SERIES 400 STAINLESS FLUSH STUDS – BULLETIN FH

FHP PEM® A286 STAINLESS STEEL FLUSH STUDS – BULLETIN FHP

Size	Punch	Anvil
440**	975200048	8001645
632**		8001644
832**		8001643
1032**		8001642
0420**		8002535
M3**		8001678
M4**		8001677
M5**		8001676
M6**		8002536

Figure P-1

Figure A-6

FH-X PEM® FLUSH STUDS WITH X-PRESS™ THREADS – BULLETIN FHX

Size	Punch	Anvil For material .060"+/1.51mm+	Anvil For material <= .059"/1.5mm
X5	975200048	970200020300	970200247300
	<i>Figure P-1</i>	<i>Figure A-3</i>	<i>Figure A-9</i>



Manual Tooling Guide

For Series LT/4® Press

NOTE: The Series LT/4 press is designed to generate a ram force of 6000 lbs / 26.7kN. The press will install fasteners that require less than 6,000 lbs / 26.7kN of installation force. Please check the fastener and workpiece material specifications for the installation force necessary for your specific application.

*LT/4 press will install fastener into aluminum. Inserting into cold rolled steel may require more than 6,000 lbs/26.7kN of force.

**LT/4 press will not install these fasteners, they require more than 6,000 lbs / 26.7kN of force for installation.

HF109 PEM® HIGH STRENGTH STUDS –

Size	Punch	Anvil (Standard Sheet)	Anvil (Thin Sheet)
M5	8014457	970200020300	8003704
M6**	8014459	970200230300	8003705
M8**	8014461	970200231300	8003706

Figure P-2

Figure A-3

Figure A-9

*Exceeds the installation force capability of the Series LT/4, Series 4 Press

**Exceeds the installation force capability of the Series 2000 and Series 3000 Presses

HFE PEM® HIGH STUDS – BULLETIN FH

Size	Punch	Anvil For material .060”+/1.51mm+	Anvil For material .040/1mm -.059”/1.5mm
*1032**	8003707	970200009300	970200246300
*0420**	8003708	970200010300	8003702
*M5**	8003710	970200020300	8003704
*M6**	8003711	970200230300	8003705
		For material .093”+/2.4mm+	For material .060/1.5mm -.093”/2.4mm
*0518**	8003709	970200011300	8003703
*M8**	8003712	970200231300	8003706

Figure P-2

Figure A-3

Figure A-9

*INSTALLATION FORCE MAY EXCEED CAPABILITIES OF SOME PEMSERTER® PRESSES SHOWN IN THIS TOOLING GUIDE. Punch and Anvil 3/4” (19mm) dia.

HFG8 PEM® HIGH STRENGTH STUDS –

Size	Punch	Anvil (Standard Sheet)	Anvil (Thin Sheet)
1032*	8014456	970200009300	970200246300
0420**	8014458	970200010300	8003702
0518**	8014460	970200011300	8003703

Figure P-2

Figure A-3

Figure A-9

*Exceeds the installation force capability of the Series LT/4 and Series 4 Presses

**Exceeds the installation force capability of the Series 2000 and Series 3000 Presses



Manual Tooling Guide

For Series LT/4® Press

NOTE: The Series LT/4 press is designed to generate a ram force of 6000 lbs / 26.7kN. The press will install fasteners that require less than 6,000 lbs / 26.7kN of installation force. Please check the fastener and workpiece material specifications for the installation force necessary for your specific application.

*LT/4 press will install fastener into aluminum. Inserting into cold rolled steel may require more than 6,000 lbs/26.7kN of force.

**LT/4 press will not install these fasteners, they require more than 6,000 lbs / 26.7kN of force for installation.

HFH, HFHS, HFHB PEM® HIGH STRENGTH STUDS – BULLETIN FH

Size	Punch		Anvil
1032	970200311400	Punch ¾” (19mm) dia Punch ¾” (19mm) dia Punch 15/16” (23.8mm) dia Punch ¾” (19mm) dia Punch ¾” (19mm) dia Punch 15/16” (23.8mm) dia Punch 1.10” (28mm) dia	970200009300
0420*	970200312400		970200010300
0518**	970200313400		970200011300
0616**	970200314400		970200004300
M5	970200311400		970200020300
M6*	970200312400		970200230300
M8**	970200313400		970200231300
M10**	970200491400		970200402300
M12	8011046		8011047

Figure P-2

Figure A-3

TFH, TFHS PEM® NON FLUSH THIN SHEET – BULLETIN FH

Size	Punch	Anvil For material .030”+/.76mm+	Anvil For material .020”/.51mm - .029”/.75mm
256	970200235400	970200005300	970200240300
440	970200236400	970200006300	970200241300
632/M3.5	970200237400	970200007300	970200243300
832	970200238400	970200008300	970200245300
1032	970200239400	970200009300	970200246300
0420	970200496400	970200010300	970200249300
M3	970200236400	970200229300	970200242300
M4	970200238400	970200019300	970200244300
M5	970200239400	970200020300	970200247300
M6	970200496400	970200230300	970200248300

Figure P-2

Figure A-3

Figure A-9

H, HN, HNL PEM® SELF-LOCKING AND NON-LOCKING NUTS – BULLETIN CL

Size	Punch	Anvil	
0420/M6	975200048	975200039	Anvil ¾” (19mm) dia
0518/M8	975200048	975200783300*	
0616/M10**	8003076	975201240*	

Figure P-1

Figure A-2 / *Figure A-5

*LARGE NUT ANVILS USE PROTRUSION TO LOCATE PART INSTEAD OF COUNTER BORE.



Manual Tooling Guide

For Series LT/4® Press

NOTE: The Series LT/4 press is designed to generate a ram force of 6000 lbs / 26.7kN. The press will install fasteners that require less than 6,000 lbs / 26.7kN of installation force. Please check the fastener and workpiece material specifications for the installation force necessary for your specific application.

*LT/4 press will install fastener into aluminum. Inserting into cold rolled steel may require more than 6,000 lbs/26.7kN of force.

**LT/4 press will not install these fasteners, they require more than 6,000 lbs / 26.7kN of force for installation.

KF2, KFS2 PEM® BROACHING NUTS – BULLETIN K

Size	Punch	Anvil
080	975200048	8015899
256/440/M2/M2.5/M3	975200048	975200904300
632/M3.5	975200048	975200035
832/M4	975200048	975200037
1032/M5	975200048	975200905300

Figure P-1

Figure A-2

KFB3 PEM® FLARE-MOUNTED THREADED STANDOFF – BULLETIN K

Size	Punch	Anvil
440 -2	975201231400	975201213300
440 -4 to -8		975200846300
440 -10 to -12		975200847300
440 -16 to -20		975200848300
440 -22 to -24		975200882300
M3 -2		975201213300
M3 -3 to -6		975200846300
M3 -8 to -10		975200847300
M3 -12 to -14		975201222300
M3 -14 to -16		975200848300
632 -2	975201232400	975201215300
632 -4 to -8		975200849300
632 -10 to -12		975200850300
632 -16 to -20		975200851300
632 -22 to -24		975200883300
632 -28 to -32		975200884300
M4 -2	975201221400	975201216300
M4 -3 to -6		975201217300
M4 -8 to -10		975201218300
M4 -12 to -14		975201220300
M4 -14 to -16		975201219300

Figure P-4

Figure A-2



Manual Tooling Guide

For Series LT/4® Press

NOTE: The Series LT/4 press is designed to generate a ram force of 6000 lbs / 26.7kN. The press will install fasteners that require less than 6,000 lbs / 26.7kN of installation force. Please check the fastener and workpiece material specifications for the installation force necessary for your specific application.

*LT/4 press will install fastener into aluminum. Inserting into cold rolled steel may require more than 6,000 lbs/26.7kN of force.

**LT/4 press will not install these fasteners, they require more than 6,000 lbs / 26.7kN of force for installation.

KFE, KFSE PEM® BROACHING STANDOFF – BULLETIN K

Size	Punch	Anvil
440/116 -4 to -8	975200048	975200846300
440/116 -10 to -12		975200847300
440/116 -16 to -20		975200848300
440/116 -20 to -24		975200882300
M3 -3 to -6		975200846300
M3 -8 to -10		975200847300
M3 -12 to -14		975201222300
M3 -14 to -16		975200848300

Figure P-1

Figure A-2

KFE, KFSE PEM® BROACHING STANDOFF – BULLETIN K

Size	Punch	Anvil
632/143 -4 to -8	975200048	975200849300
632/143 -10 to -12		975200850300
632/143 -16 to -20		975200851300
632/143 -22 to -24		975200883300
632/143 -28 to -32		975200884300
3.6 -3 to -6		975200849300
3.6 -8 to -10		975200850300
3.6 -12 to -16		975200851300
4.2 -2		975201216300
4.2 -3 to -6		975201217300
4.2 -8 to -10		975201218300
4.2 -12 to -14		975201220300
4.2 -14 to -16		975201219300

Figure P-1

Figure A-2

KFH PEM® BROACHING STUDS – BULLETIN K

Size	Punch	Anvil
440	975200048	970200006300
632		970200007300
832		970200008300
1032		970200009300
M3		970200229300
M4		970200019300
M5		970200020300

Figure P-1

Figure A-3



Manual Tooling Guide

For Series LT/4® Press

NOTE: The Series LT/4 press is designed to generate a ram force of 6000 lbs / 26.7kN. The press will install fasteners that require less than 6,000 lbs / 26.7kN of installation force. Please check the fastener and workpiece material specifications for the installation force necessary for your specific application.

*LT/4 press will install fastener into aluminum. Inserting into cold rolled steel may require more than 6,000 lbs/26.7kN of force.

**LT/4 press will not install these fasteners, they require more than 6,000 lbs / 26.7kN of force for installation.

KPS6 PEM® SELF-EXPANDING FOILGUARD® FASTENERS – BULLETIN K

Size	Punch	Anvil
440 (-4 TO -8)	975200048	975200846300
440 (-10 TO -12)		975200847300
440 (-16 TO -20)		975200848300
632 (-4 TO -8)		975200849300
632 (-10 TO -12)		975200850300
632 (-16 TO -20)		975200851300
832 (-4 TO -8)		975201217300
832 (-10 TO -12)		975201218300
832 (-16 TO -20)		975201220300
1032 (-4 TO -8)		975201234300
1032 (-10 TO -12)		975201236300
1032 (-16 TO -20)		975201237300
M3 (-3 TO -6)		975200846300
M3 (-8 TO -10)		975200847300
M3 (-12 TO -14)		975200848300
M4 (-3 TO -6)		975201217300
M4 (-8 TO -10)		975201218300
M4 (-12 TO -14)		975201220300
M5 (-3 TO -6)		975201234300
M5 (-8 TO -10)		975201236300
M5 (-12)	975201237300	

Figure P-1

Figure A-2

KSSB PEM® BROACHING SNAP-TOP STANDOFFS– BULLETIN SSA

Size	Punch	Anvil
156 (-8 TO -32) 4mm (-8 TO -25)	975200048	970200015300

Figure P-1

Figure A-3

LK, LKS, LKA PEM® SELF-LOCKING NUTS– BULLETIN LK

Size	Punch	Anvil
2-56/M2.5	975200048	975200015
440/M3		975200016
632		975201242
832/M4		975201241
1032/M5		975200019

Figure P-1

Figure A-4



Manual Tooling Guide

For Series LT/4® Press

NOTE: The Series LT/4 press is designed to generate a ram force of 6000 lbs / 26.7kN. The press will install fasteners that require less than 6,000 lbs / 26.7kN of installation force. Please check the fastener and workpiece material specifications for the installation force necessary for your specific application.

*LT/4 press will install fastener into aluminum. Inserting into cold rolled steel may require more than 6,000 lbs/26.7kN of force.

**LT/4 press will not install these fasteners, they require more than 6,000 lbs / 26.7kN of force for installation.

MPP PEM® MINIATURE PINS-BULLETIN

Size	Punch	Anvil
1MM	8014167	8014168
1.5MM		8014169
2MM		8014170

Figure P-1

Figure A-3

MS04 PEM® MINIATURE SELF-CLINCHING STANDOFFS

Size	Punch	Anvil
080/ M1/M1.2/M1.4/M1.6	975200997	8015796
256/ M2		0815797

Figure P-1

Figure A-3

NFPC, NFPA PEM® INSERTS FOR PLASTICS – BULLETIN SI

Size	Punch	Anvil
ALL SIZES	975200048	975200046

Figure P-1

Figure A-11

FLUSH-MOUNTED PANEL SCREW COMPONENTS

PF10 COMPONENTS – BULLETIN PF

PR10 – FLUSH-MOUNTED RETAINER

Size	Punch	Anvil
440/M3	975200048	970200013300
632		970200011300
832/M4		970200393300
1032/M5		970200004300

Figure P-1

Figure A-3

N10 SELF-CLINCHING RECEPTACLE NUTS

Size	Punch	Anvil
440/M3	975200048	8006124
632		8006735
832/M4		8006736
1032/M5		8006174

Figure P-1

Figure A-4



Manual Tooling Guide

For Series LT/4® Press

NOTE: The Series LT/4 press is designed to generate a ram force of 6000 lbs / 26.7kN. The press will install fasteners that require less than 6,000 lbs / 26.7kN of installation force. Please check the fastener and workpiece material specifications for the installation force necessary for your specific application.

*LT/4 press will install fastener into aluminum. Inserting into cold rolled steel may require more than 6,000 lbs/26.7kN of force.

**LT/4 press will not install these fasteners, they require more than 6,000 lbs / 26.7kN of force for installation.

PF11, PF11PM, PF13, PF14 PEM® PANEL FASTENER – BULLETIN PF

Size	Punch	Anvil
440/M3	8003518	8003521
632/M3.5	8003519	8003522
832/M4	8003520	8003523
1032/M5	8004350	8003523
0420/M6	8004352	8004351

Figure P-3

Figure A-2

PF11MF PEM® FLARING PANEL FASTENER

Size	Punch	Anvil
440/M3	8013670	8003521
632/M3.5	8013671	8003522
832/M4	8013672	8003523
1032/M5	8013672	8003523
0420/M6	8013674	8004351

Figure P-

Figure A-2

PF11MW PEM® PANEL FASTENER W/WASHER

Size	Punch	Anvil
440/M3	8014304	8003521
632/M3.5	8014305	8003522
832/M4	8014306	8003523
1032/M5	8014306	8003523
0420/M6	8014307	8004351

Figure P-9

Figure A-2

PF30, PF31, PF32, PF50, PF60 PEM® LOW PROFILE PANEL FASTENER – BULLETIN PF

Size	Punch	Anvil
440/M3	975200060	975201060
632	975200061	975201061
832/M4	975200062	975201062
1032/M5	975200063	975201063
0420/M6	975200064	975201064

Figure P-3

Figure A-2



Manual Tooling Guide

For Series LT/4® Press

NOTE: The Series LT/4 press is designed to generate a ram force of 6000 lbs / 26.7kN. The press will install fasteners that require less than 6,000 lbs / 26.7kN of installation force. Please check the fastener and workpiece material specifications for the installation force necessary for your specific application.

*LT/4 press will install fastener into aluminum. Inserting into cold rolled steel may require more than 6,000 lbs/26.7kN of force.

**LT/4 press will not install these fasteners, they require more than 6,000 lbs / 26.7kN of force for installation.

PFC2, PFC2P, PFK, PFS2 PEM® PANEL FASTENER – BULLETIN PF

Size	Punch	Anvil
440/M3	975200060	975200026
632	975200061	975200027
832/M4	975200062	975200028
1032/M5	975200063	975200029
0420/M6	975200064	975200030

Figure P-3

Figure A-2

PFC4 PEM® PANEL FASTENER – BULLETIN PF

Size	Punch	Anvil
440/M3	975200060	975200027
632	975200061	975201243
832/M4	975200062	975200029
1032/M5	975200063	975201244

Figure P-3

Figure A-2

PFF PEM® FLOATING PANEL FASTENER – BULLETIN PF

Size	Punch	Anvil
1032/M5	8006702	8006825
1224	8006703	8006701
M6	8006704	

Figure P-6

Figure A-10

PFHV PEM® PANEL FASTENER – BULLETIN PF

Size	Punch	Anvil
440/M3	970200006400	8004688
632/M3.5	970200007400	8004689
832/M4	975200060	8005439

Figure P-3

Figure A-2

PFP PEM® PANEL FASTENER – BULLETIN PF

Size	Punch	Anvil
440/M3	8005440	8005413
632	8005441	8005413
832/M4	8005442	8005414
1032/M5	8005993	8005414

Figure P-3

Figure A-2

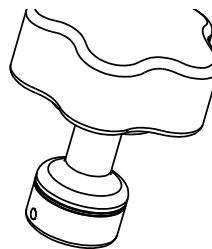

NOTE: The Series LT/4 press is designed to generate a ram force to install fasteners that require less than 6,000 lbs / 26.7kN of installation force. The press will check the fastener and workpiece material specifications for the installation force necessary for your specific application.

*LT/4 press will install fastener into aluminum. Inserting into cold rolled steel may require more than 6,000 lbs/26.7kN of force.
**LT/4 press will not install these fasteners, they require more than 6,000 lbs / 26.7kN of force for installation.

The press will check the fastener and workpiece material specifications for the installation force necessary for your specific application.

PFS PEM® SNAP-IN PANEL FASTENER – BULLETIN PF

Size	Hand Tool Assembly
440/M3	8006347
632/M3.5	8006347
832/M4	8006348

PFVM PEM® PANEL FASTENER – BULLETIN PF

Size	Punch	Anvil
440/M3	8003518	8016175
632	8003519	8016176
832/M4	8003520	8016177

Figure P-3

Figure A-2

PFVMF PEM® PANEL FASTENER – BULLETIN PF

Size	Punch	Anvil
440/M3	8013670	8016175
632	8013671	8016176
832/M4	8013672	8016177

Figure P-3

Figure A-2

PL, PLC PEM-HEX® SELF-LOCKING NUTS – BULLETIN PL

Size	Punch	Anvil
440/M3	975200048	975200011
632/M3.5		975200012
832/M4		975200013
1032/M5		975200014

Figure P-1

Figure A-4

PPB, PFLB, PKB PEM® INSERTS FOR PLASTICS – BULLETIN SI
– TOOLING TO BE DETERMINED

PTL2 PEM® SPRING-LOADED PLUNGER ASSEMBLIES – BULLETIN PF

Size	Punch	Anvil
04	970200013300	975201245

Figure P-3

Figure A-4



Manual Tooling Guide

For Series LT/4® Press

NOTE: The Series LT/4 press is designed to generate a ram force of 6000 lbs / 26.7kN. The press will install fasteners that require less than 6,000 lbs / 26.7kN of installation force. Please check the fastener and workpiece material specifications for the installation force necessary for your specific application.

*LT/4 press will install fastener into aluminum. Inserting into cold rolled steel may require more than 6,000 lbs/26.7kN of force.

**LT/4 press will not install these fasteners, they require more than 6,000 lbs / 26.7kN of force for installation.

RAA, RAS PEM® R' ANGLE CLINCH FASTENER – BULLETIN RA

Size	Punch	Anvil
440	8003076	8002711
632		8002712
832		8003642
M3		8002713
M4		8002714

*Figure P-1 -
1"(25.4mm) dia*

*Figure A-8 -
1"(25.4mm) dia*

SCB/SCBJ PEM® SPINNING CLINCH BOLT – Bulletin SCB

Size	Punch	Anvil
#4	8012730	970200006300
#6	8012731	970200007300
#8	8012732	970200008300
M3	8012730	970200229300
M3.5	8012731	970200007300
M4	8012732	970200019300

Figure P-3

Figure A-3

SCBR PEM® MAGNETIC PUNCH ASSEMBLIES – BULLETIN

Size	Punch	Anvil
440	8016210	970200006300
632	8016211	970200007300
832	8016212	970200008300
M3	8016213	970200229300
M4	8016214	970200019300

Figure P-1

Figure A-8 -

SF, SFP, SFK PEM® SPOT FAST – BULLETIN SF

Size	Punch	Anvil
3-0.8	975200048	975200046
3-1.0		
3-1.2		
3-1.6		
5-0.8		
5-1.0		
5-1.2		
5-1.6		

Figure P-1 -

Figure A-1



Manual Tooling Guide

For Series LT/4® Press

NOTE: The Series LT/4 press is designed to generate a ram force of 6000 lbs / 26.7kN. The press will install fasteners that require less than 6,000 lbs / 26.7kN of installation force. Please check the fastener and workpiece material specifications for the installation force necessary for your specific application.

*LT/4 press will install fastener into aluminum. Inserting into cold rolled steel may require more than 6,000 lbs/26.7kN of force.

**LT/4 press will not install these fasteners, they require more than 6,000 lbs / 26.7kN of force for installation.

SFW PEM® SPOT FAST – BULLETIN SFW

Size	Punch	Anvil
3-0.8	975200048	970200229300 & 975200046
3-1.0		
3-1.2		
3-1.6		
5-0.8		970200020300 & 975200046
5-1.0		
5-1.2		
5-1.6		

Figure P-1 -

Figure A-4 & A-1

SGPC PEM® SWAGING COLLAR STUDS – BULLETIN SGPC

Size	Punch	Anvil
256	8015111	8016983
440	8015112	8016984
632	8015113	8016985
832	8015114	8016986
1032	8015115	8016987
0420	8015116	8016988
M2.5	8015117	8016989
M3	8015118	8016990
M4	8015119	8016991
M5	8015120	8016992
M6	8015121	8016993

Figure P-2

Figure A-3



Manual Tooling Guide

For Series LT/4® Press

NOTE: The Series LT/4 press is designed to generate a ram force of 6000 lbs / 26.7kN. The press will install fasteners that require less than 6,000 lbs / 26.7kN of installation force. Please check the fastener and workpiece material specifications for the installation force necessary for your specific application.

*LT/4 press will install fastener into aluminum. Inserting into cold rolled steel may require more than 6,000 lbs/26.7kN of force.

**LT/4 press will not install these fasteners, they require more than 6,000 lbs / 26.7kN of force for installation.

SKC-6060 (SKC 61.5) PEM® KEYHOLE® SELF-CLINCHING STANDOFFS – BULLETIN SK

Size	Punch	Anvil
6060 / 61.5	975200048	970200012300

Figure P-1

Figure A-3

SKC-F1.5 PEM® KEYHOLE® INVERTED SELF-CLINCHING STANDOFFS – BULLETIN SK

Size	Punch	Anvil
F1.5	975200048	8012608

Figure P-1

Figure A-3

SL PEM® SELF-CLINCHING LOCK NUTS – BULLETIN CL

Size	Punch	Anvil
440/M3	975200048	975200034
632/M3.5*		975200035
832/M4*		975200036
1032/M5*		975200037
0420/M6*		975200038

Figure P-1

Figure A-2

NOTE: THESE ANVILS ARE SAME AS CLS, S ANVILS.

SMPS PEM® SELF-CLINCHING NUT FOR ULTRA THIN SHEETS – BULLETIN CL

Size	Punch	Anvil
2/440/M2.5/M3	975200048	975200904300
632/M3.5		975200034

Figure P-1

Figure A-2

SO, SOA, SOS, SON, BSO, BSOA, BSOS, BSON PEM® STANDOFFS – BULLETIN SO

SOAG, SOSG PEM® STANDOFFS – BULLETIN K

Size	Punch	Anvil
2/3/440/M2/M2.5/M3	975200048	970200487300
632/6440/3.5M3/M3.5		970200012300
832/8632/M4		970200013300
1032/M5		970200013300
0420/M6		970200393300

Figure P-1

Figure A-3



NOTE: The Series LT/4 press is designed to generate a ram force of 6000 lbs / 26.7kN. The press will install fasteners that require less than 6,000 lbs / 26.7kN of installation force. Please check the fastener and workpiece material specifications for the installation force necessary for your specific application.

*LT/4 press will install fastener into aluminum. Inserting into cold rolled steel may require more than 6,000 lbs/26.7kN of force.

**LT/4 press will not install these fasteners, they require more than 6,000 lbs / 26.7kN of force for installation.

SP PEM® 300 STAINLESS STEEL SELF-CLINCHING NUTS – BULLETIN CL

Size	Punch (Grooved Version)	Anvil (Grooved Version)	Punch (Stamped Version)	Anvil (Stamped Version)
440	8002691	8002687	975200048	8012821
632**	8002692	8002688		8012822
832**	8002693	8002689		8012823
1032**	8002694	8002690		8012824
0420**	975200048	975200038		8012825
0518**	975000048	975200039	8003076	8015359
0616**	975200048	975200045	8003076	8015863
M2.5	8006361	8002687	8003076	8014859
M2/M3	8002695	8002687		8012821
M3.5**	8002696	8002688		8012822
M4**	8002697	8002689		8012823
M5**	8002698	8002690		8012824
M6**	975200048	975200038		8012825
M8**	975200048	975200039	8003076	80153670
M10**	975200901400	8005682	8003076	8015886

Pin & Figure P-1

Figure A-7 & Figure A-2

Figure P-1

Figure A-2

NOTE: These punch & anvils have special geometry for maximum clinch performance into stainless steel and alignment, except for 0420/M6, which does not require the special geometry.



SSA, SSS, SSC, KSSB PEM® SNAP-TOP STANDOFFS – BULLETIN SSA

Size	Punch	Anvil
ALL	975200048	970200015300

Figure P-1

Figure A-4



Manual Tooling Guide

For Series LT/4® Press

NOTE: The Series LT/4 press is designed to generate a ram force of 6000 lbs / 26.7kN. The press will install fasteners that require less than 6,000 lbs / 26.7kN of installation force. Please check the fastener and workpiece material specifications for the installation force necessary for your specific application.

*LT/4 press will install fastener into aluminum. Inserting into cold rolled steel may require more than 6,000 lbs/26.7kN of force.

**LT/4 press will not install these fasteners, they require more than 6,000 lbs / 26.7kN of force for installation.

TDO PEM® CABLE TIE HOOKS-CLINCHING – BULLETIN TD

Size	Punch	Anvil
40	975200048	8006865
		8006864
120	8003076 (1" dia)	8006863

Figure P-1

Figure A-11

TPS PEM® FLUSH-MOUNTED PILOT PINS – BULLETIN FH

Size	Punch 4"/101.6mm Long	Anvil For material .060"/+1.7mm+	Anvil For material .040-.060"/ 1mm – 1.7mm
.125 (.130)	975200048	8003278	8003284
.187 (.192)		8003279	8003285
.250 (.255)		8003280	8003286
3 mm (.122)		8008095	8008096
4 mm (.161)		8003281	8003287
5 mm (.201)		8003282	8003288
6 mm (.290)		8003283	8003289

Figure P-1

Figure A-3

Figure A-9

TPXS PEM® FLUSH-MOUNTED PILOT PINS – BULLETIN FH

Size	Punch 4"/101.6mm Long	Anvil For material .060"/+1.7mm+	Anvil For material .040-.060"/ 1mm – 1.7mm
3 mm (.122)	975200048	8008095	8008096

Figure P-1

Figure A-3

Figure A-9

TSO, TSOS, TSOA PEM® THREADED STANDOFFS FOR THIN SHEETS- BULLETIN SO

Size	Punch	Anvil For material .032"/+0.81mm+	Anvil For material .025-.032" / .63mm - .81/.75mm
256	975200048	970200008300	8003291
440		970200008300	8003291
6256		970200012300	8003292
632		970200012300	8003292
6440		970200012300	8003292
M2.5		970200008300	8003291
M3		970200008300	8003291
6M25		970200012300	8003292
6M3		970200012300	8003292
M35		970200012300	8003292

Figure P-1

Figure A-3

Figure A-9



Manual Tooling Guide

For Series LT/4® Press

NOTE: The Series LT/4 press is designed to generate a ram force of 6000 lbs / 26.7kN. The press will install fasteners that require less than 6,000 lbs / 26.7kN of installation force. Please check the fastener and workpiece material specifications for the installation force necessary for your specific application.

*LT/4 press will install fastener into aluminum. Inserting into cold rolled steel may require more than 6,000 lbs/26.7kN of force.

**LT/4 press will not install these fasteners, they require more than 6,000 lbs / 26.7kN of force for installation.

TY-D PEM® CABLE TIE-MOUNT SELF-CLINCHING – BULLETIN TD

Size	Punch	Anvil
40	8003076	8006136
60		8006137
175		8006138

Figure P-1 (1" dia)

Figure A-8 (1" dia)

U, UL PEM® MINIATURE SELF-CLINCHING FASTENERS – BULLETIN FE

Size	Punch	Anvil
256/M2	975200048	975200020

Figure P-1

Figure A-4

TURRET ANVILS

STUDS – FH 4 – ¼-20 STANDOFFS – SO 4 AND 6	980020018
STUDS – FH M2.5 – M6	980020047
STANDOFFS – SO 4/M3/6/M3.5/8/M4/10/M5	980020053
NUTS – S AND CLS 2 – ¼-20 / M2 – M6	980020019
*SPECIAL TURRET ANVILS AVAILABLE UPON REQUEST	

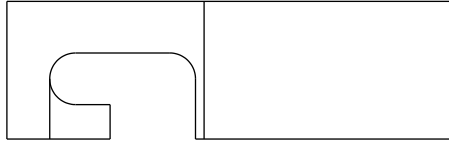

side

NOTE: The Series LT/4 press is designed to generate a ram force of 6000 lbs / 26.7kN. The press will install fasteners that require less than 6,000 lbs / 26.7kN of installation force. Please check the fastener and workpiece material specifications for the installation force necessary for your specific application.

*LT/4 press will install fastener into aluminum. Inserting into cold rolled steel may require more than 6,000 lbs/26.7kN of force.
**LT/4 press will not install these fasteners, they require more than 6,000 lbs / 26.7kN of force for installation.

**QX4™ TURRET TOOL SYSTEM
(SERIES 4® and SERIESLT/4™ ONLY)**



KIT 8011600

The PEMSERTER® QX4™ Turret Tool System provides an efficient method to quickly change between four different anvil tools. The one-handed operation of this tool allows an operator to install four different types and/or sizes of fasteners with one set-up. The QX4™ Turret Tool System can be easily installed on all new and existing PEMSERTER® Series 4® and Series LT/4™ presses.

KIT INCLUDES: Anvil Holder, QX4 Table, Color Coded Parts Tray Assembly and 3" Flat Punch 975200046.

TOOLS FOR SERIES 4 & LT/4 BOTTOM MOUNT REVERSE FLANGE ANVIL HOLDER

INCLUDED IN KIT:

PUNCH	975201037825 – 8.25" LONG
ANVIL FLAT	975200725019 - .190" LONG

ADDITIONAL ANVILS:

ANVIL S-440/M3	975200841019 - .190" LONG
ANVIL S-632/M3.5	975200842019 - .190" LONG
ANVIL S-832/M4	975200843019 - .190" LONG
ANVIL S-1032/M5	975200844019 - .190" LONG
ANVIL S-12-24	975200845019 - .190" LONG

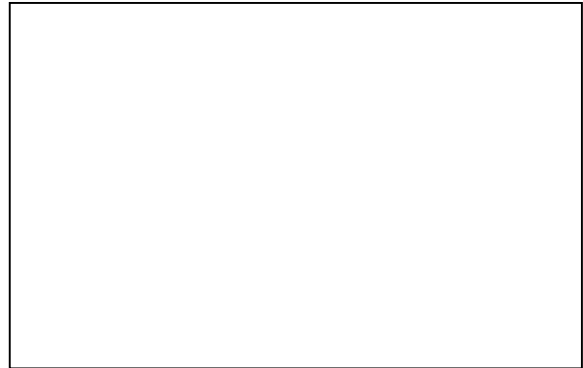

WORKPIECE ALIGNMENT PLATES KIT PART # 8004682 CONTAINS:

ALIGNMENT PLATE ROUND	980020059
ALIGNMENT PLATE RECTANGULAR	980020060



Manual Tooling Guide

For Series LT/4® Press

NOTE: The Series LT/4 press is designed to generate a ram force of 6000 lbs / 26.7kN. The press will install fasteners that require less than 6,000 lbs / 26.7kN of installation force. Please check the fastener and workpiece material specifications for the installation force necessary for your specific application.

*LT/4 press will install fastener into aluminum. Inserting into cold rolled steel may require more than 6,000 lbs/26.7kN of force.

**LT/4 press will not install these fasteners, they require more than 6,000 lbs / 26.7kN of force for installation.

Reference Page 5 for the items listed below for diagrams:

TOOLING ADAPTER FOR .500” DIA ANVIL HOLDER & PUNCH ADAPTER –
PART# 8007647 (Must be purchased in Qty 2)

ANVIL ADAPTER FOR .500” DIA SHANKS – PART# 8010778

ANVIL ADAPTER FOR .625” DIA SHANKS – PART# 8010779

ANVIL ADAPTER FOR .750” DIA SHANKS – PART# 8010780

.500” DIA FLAT PUNCHES AVAILABLE:

PART# 8010781 - .500” DIA X 5.25” LONG

PART# 8010782 - .500” DIA X 4.5” LONG

PART# 8010783 - .500” DIA X 3.75” LONG

To Determine which of the above flat punches to use with each Anvil Adapter for use with the Series 4 & Series LT/4 presses: (Total length of tooling = 7”)

Anvil Adapter is .75” tall, allowing for anvil to sit in .50” leaving .25” to be accounted for tooling height.

Anvil Adapter Height	Anvil Length	½” Dia Flat Punch
.25”	1.5”	8010781 (5.25” Long)
.25”	2.25”	8010782 (4.50” Long)
.25”	3”	8010783 (3.75” Long)

NOTE: The Series LT/4 press is designed to generate a ram force of 6000 lbs / 26.7kN. The press will install fasteners that require less than 6,000 lbs / 26.7kN of installation force. Please check the fastener and workpiece material specifications for the installation force necessary for your specific application.

*LT/4 press will install fastener into aluminum. Inserting into cold rolled steel may require more than 6,000 lbs/26.7kN of force.

**LT/4 press will not install these fasteners, they require more than 6,000 lbs / 26.7kN of force for installation.

TOOLING FOR SWAGE STANDOFFS

To determine the counterbore dimensions for the manual anvil, follow this formula:

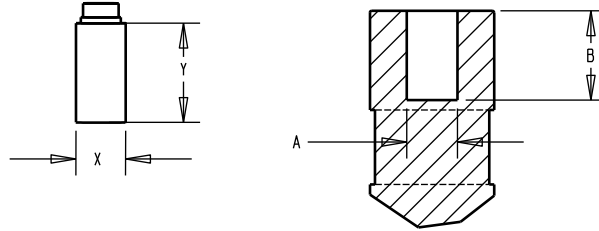

A dimension = X (dia of fastener body) + .005 tolerance of “+.005 -.000”

B dimension = Y (length of fastener body) - .010

The list below references all of the manual anvils that have been designed for swage standoffs:

Anvil Part No.	Counterbore	
	Dia	Depth
8006936	.192	.150
8008455	.192	.235
8008454	.192	.675
8006946	.242	.150
8006937	.242	.580
8006195	.245	.485
8008459	.255	.080
8006935	.255	.450
8006190	.255	1.20
8006926	.260	.900
8009970	.380	.490
8009971	.380	.740

NOTE: The Series LT/4 press is designed to generate a ram force of 6000 lbs / 26.7kN. The press will install fasteners that require less than 6,000 lbs / 26.7kN of installation force. Please check the fastener and workpiece material specifications for the installation force necessary for your specific application.

LT/4 press will install fastener into aluminum. Inserting into cold rolled steel may require more than 6,000 lbs/26.7kN of force.
 **LT/4 press will not install these fasteners, they require more than 6,000 lbs / 26.7kN of force for installation.

Insert Manufacturer punch here

Punch Adapter

This adapter is for holding the manufacturer punches so that they can properly install the swage standoffs.

Adapter Part No.	Adapter Hole Dia	Adapter Hole Depth*
8007619	.501	2.00"
8009613	.501	1.50"
8009614	.501	1.20"

*The depth of the adapter hole will vary depending on the length of the Manufacturer tooling being adapted to our tooling. The length of the tooling must measure up to the standard 7".

The punches are inserted into the PEMSERTER® punch adapter and are held in with Qty 1 - SSS #4-40 x 1/4 LG.

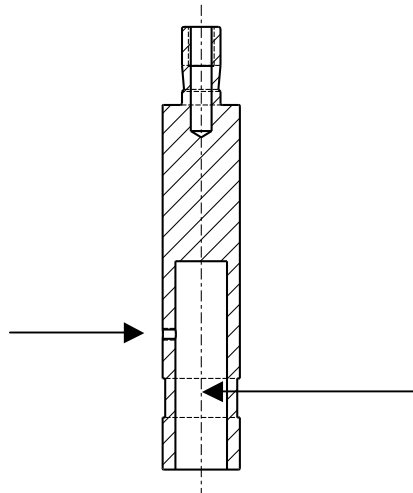

The manufacturer punches contain the rounded geometry for installing the swage standoffs (see below):

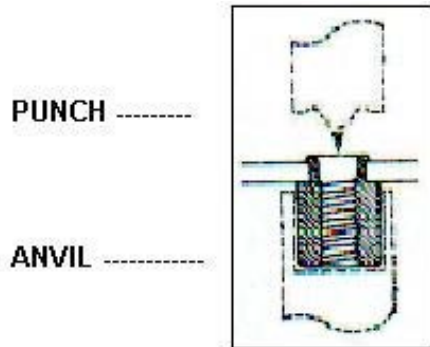



Manual Tooling Guide

For Series LT/4® Press

NOTE: The Series LT/4 press is designed to generate a ram force of 6000 lbs / 26.7kN. The press will install fasteners that require less than 6,000 lbs / 26.7kN of installation force. Please check the fastener and workpiece material specifications for the installation force necessary for your specific application.

*LT/4 press will install fastener into aluminum. Inserting into cold rolled steel may require more than 6,000 lbs/26.7kN of force.

**LT/4 press will not install these fasteners, they require more than 6,000 lbs / 26.7kN of force for installation.

For Series 2000, Series 4 & Series LT4 presses:



Important: The ram must contact the fastener fully in the workpiece (but not installed) and both the fastener and workpiece must be flat to the punch and anvil. The gap between the punch and the anvil must not exceed 5.5mm (7/32”) to conform to internationally recognized safety standards. This means that the stacked height of the fastener and the workpiece before installation must not exceed 5.5mm (7/32”). These include standards published by ISO, ANSI, OSHA, CEN and CSA.

PRESS ACCESSORIES:

Part Number	Description	Features and Benefits
8005538 (120V) (US) 8005539 (220V) (EUROPE)	Industrial Work Light	Flexible, Efficient Coverage of Working Area Bright 20W Halogen Bulb Magnetic Base Mounts to Frame 120V/220V models available
08005537	Anti-Fatigue Work Mat	Solid polyurethane nodule design increases blood circulation and reduces cumulative trauma disorders associated with prolonged standing. Chemical Resistant Durable and easy to clean Shock absorbent with Tapered Edges 24" by 36" Two Year Wear Warranty
8005531	Industrial Work Seat	Ergonomic design improves comfort and increases worker productivity Four Easy to use Height (16" to 32") and Tilt Adjustments Durable Polyurethane Seat Foot Rest Step Rail Built tough for industrial environment Swivel Stop Feature makes getting on and off the chair easy and safe Five Year, Three shift Warranty